

# OWNER'S MANUAL



**FREEDOM**  
Concepts  
Inc.™

[freedomconcepts.com](http://freedomconcepts.com)





Congratulations on the purchase of your new Freedom Concepts bike!

This Owner's Manual refers to our complete bike line and has been color-coded to easily reference the options and components that apply to your bike.

If the manual and online video links do not answer your questions, please feel free to contact our customer service department at 1-800-661-9915.

We hope you enjoy your bike for many years to come!

*Remember to always "Cycle Hard" and "Chill-Out" often!*



**IMPORTANT!** Keep this manual for future reference. Additional copies available at [www.freedomconcepts.com](http://www.freedomconcepts.com)



## WARNING



**Read and understand these instructions for use before using the device. If the instructions are not followed serious injury could occur.**

- ✓ This is a therapy device, consult a qualified professional for the proper setup, application and safety of this product for each user.
- ✓ **Device Can Tip** and cause rider to fall. To avoid injury:
  - ✓ Supervise rider at all times.
  - ✓ Secure rider by fastening all seat straps and foot straps before moving device.
  - ✓ Rider should wear protective helmet and shoes.
  - ✓ Take corners slowly, speed should not exceed a walking pace.
  - ✓ Avoid uneven surfaces, obstacles on the ground, stairways and pools.
  - ✓ Do not use device with riders outside the weight limits specified.
- ✓ Keep hands, feet and loose clothing away from moving chain and sprockets. Severe injury can occur.
- ✓ Engage the parking brake while transferring rider on or off the bike and while the bike is not in use. If the brake is not applied the bike can roll unexpectedly and cause injury or damage.
- ✓ Ensure all quick release clamps are closed and tight before positioning rider on device. Improperly adjusted quick releases can cause the seat and/or handlebar to move unexpectedly. Quick releases are located at the base of the handlebars and on both seat posts.
- ✓ Do not adjust seat height while rider is seated on the device.
- ✓ Always fasten seatbelt when the butterfly chest harness or headrest is used, to prevent strangulation, head entrapment or other injuries.
- ✓ Do not alter or modify any component on the device. Freedom Concepts does not accept responsibility for any modifications or alterations made to the device after it leaves the factory. Customers modifying or altering the device do so at their own risk.
- ✓ Inspect this product and accessories regularly for loose or missing screws, metal fatigue, cracks, broken welds, missing attachments, general instability or other signs of excessive wear.



© 2018 FREEDOM CONCEPTS INC.





freedomconcepts.com/warranty  
**Register your bike online  
 for a chance to win cool prizes!**

Model # \_\_\_\_\_

Serial # \_\_\_\_\_

Date of Purchase: \_\_\_\_\_

Visit us at  
[www.FreedomConcepts.com](http://www.FreedomConcepts.com)

Find us on Facebook.

Tweet us on Twitter.

Visit us on YouTube.

## Table of Contents



Looking for something in particular? Use our handy table of contents to source the exact page for what you need.

*Please note: not all instructions are relevant to each bike. Use the quick color-code reference from page 3 to ensure the instructions you are looking at are applicable to your bike's needs. Also, follow our QR Codes for online video tutorials for repairs.*

### Welcome ..... 1-2

- Welcome to Freedom
- Safety Considerations
- Bike Registration
- Overview

### Models ..... 3

- Discovery • Adventurer
- Excursion • Odyssey
- Expedition
- Color-code Reference

### Straps, Harnesses and Foot Plates ..... 4-5

- Seat Belts and Ankle Straps
- Chest Harness
- Velcro Straps
- Toe-up Pulley Adjustments
- Foot Plate Adjustments

### Seats ..... 6-7

- Adjusting Height
- Adjusting Incline
- T-Bar Seat Installation
- Head Support
- Swing Away Lateral Trunk Support
- Head Rest

### Steering ..... 8-11

- Handlebar/Grip
- Alignment
- Self-Centering Spring
- "U" Bar
- Quick Release Lever
- Handle Cable Tension
- Tandem Cable Tension
- Rear Steering Handlebar Column.

### Gear Shifting And Crank/Sprocket Adjustments ..... 12-15

- Hand Grip Shifting
- Gear Box Hub
- Thumb Pedal Control Shifter
- Rear Control Gear Transfer
- Thumb/Finger Shifter
- Multi-Speed Shifter
- Rear Sprocket
- Electronic Motor
- Multi-Length Crank
- Bottom Bracket Crank
- Pedal Spacers

### Braking ..... 15-17

- Hand Brake Tension
- Dual Cable Junction
- Parking Back Brake
- Caliper Tension
- V-Brake Tension
- Disc Brake Tension

### Wheels and Tires ..... 18

- Tire & Wheel Options
- Removable Rear Wheel

### Customized Options & Accessories ..... 19-20

- Maintenance Guidelines
- Neoprene Chest Harness
- Abductor Leg Support
- Adduction Leg Support
- Stationary Trainer
- Communication Tray
- Assorted Accessories Listing
- Maintenance Guidelines

### Warranty ..... 21

### Reward Program ..... 22

### Mission ..... 22



## Color-Code Quick Reference

To help you better, we have color-coded all instructions pertaining to each bike. When searching the manual, look for the quick color reference to find the information relevant to you and your bike.



All products and services are subject to change at anytime without notice, at the sole discretion of Freedom Concepts. Freedom Concepts reserves the right to discontinue any product at any time.

## Series Models

Freedom Concepts prides itself in enabling children of all ages, and even those who are just young at heart, to have fun. Cycling provides so many physical and psychological benefits. It offers the advancement of motor skills, strengthens one's core muscles, develops confidence, and offers independence. Stay connected with Freedom Concepts as we are constantly researching and developing new and better ways for all to **create a cycle of mobility.**



### DISCOVERY SERIES

(DCP MINI, DCP 12, DCP16)

- Rider Age ..... 18 mon.- 14 years
- Rider Inseam .. 6" - 26" (15 cm - 66 cm)
- Max Load ..... 60 lbs - 150 lbs (27 kg - 68 kg)
- Bike Weight..... 40 lbs - 45 lbs (18 kg - 20.5 kg)
- Wheel Size..... 12" - 16" (30.5 cm - 40.5 cm)
- Length\* ..... 42" - 48" (106 cm - 122 cm)
- \*with Rear Steering™ add 12" (30.5 cm)*
- Width ..... 29" (73.5cm)



### ADVENTURER SERIES

(AS 2000, AS 2000JR, AS 2000K, AS 2000N, AS 2600)

- Rider Age ..... 14+ years
- Rider Inseam .. 23" - 32" (58 cm - 81 cm)
- Max Load ..... 225 lbs - 350 lbs (102 kg - 159 kg)
- Bike Weight..... 65 lbs - 68 lbs (29.5 kg - 31 kg)
- Wheel Size..... 20" - 26" (50 cm - 66 cm)
- Length\* ..... 62" - 72" (157.5 cm - 183 cm)
- \*with Rear Steer™ add 12" (30.5 cm)*
- Width ..... 31" - 35" (78.5 cm - 89 cm)



### ODYSSEY SERIES

(ASR 2011)

- Rider Age ..... 12+ years
- Rider Inseam .. 19" - 34" (48 cm - 86 cm)
- Max Load ..... 225 lbs (102 kg)
- Bike Weight..... 53 lbs (24 kg)
- Wheel Size..... 20" (51 cm)
- Length\* ..... 77" (195.5 cm)
- \*with Rear Steering™ add 12" (30.5 cm)*
- Width ..... 34" (86 cm)



### EXCURSION SERIES

(ET 2611)

- Rider Age ..... 7+ years
- Inseam..... 16" - 30" (40.5 cm - 76 cm)
- Max Load ..... 400 lbs (181.5 kg)
- Bike Weight..... 85 lbs (38.5 kg)
- Wheel Size ..... 24"/26" (61 cm/66 cm)
- Length ..... 101" (256.5 cm)
- Width ..... 38" (96.5 cm)



### EXPEDITION SERIES

(EHD U16N, EHD U16WG)

- Rider Age ..... 7-14 years
- Rider Inseam .... 13" - 26" (33 cm - 66 cm)
- Max Load ..... 150lbs (68 kg)
- Bike Weight..... 50 lbs (22.5 kg)
- Wheel Size ..... 16" (40.5 cm)
- Length ..... 50" (127 cm)
- \*with Rear Steering™ add 12" (30.5 cm)*
- Width ..... 29" - 34" (73.5 cm - 86 cm)





## SEAT BELT & NEOPRENE ANKLE STRAP ADJUSTMENT

1. Loop strap as shown and pull (A) to tighten to desired length.
2. To close, push buckle (B) into lock clasp (C).
3. To release, squeeze buckle teeth (B) from side of lock clasp (C) and pull out buckle strap.

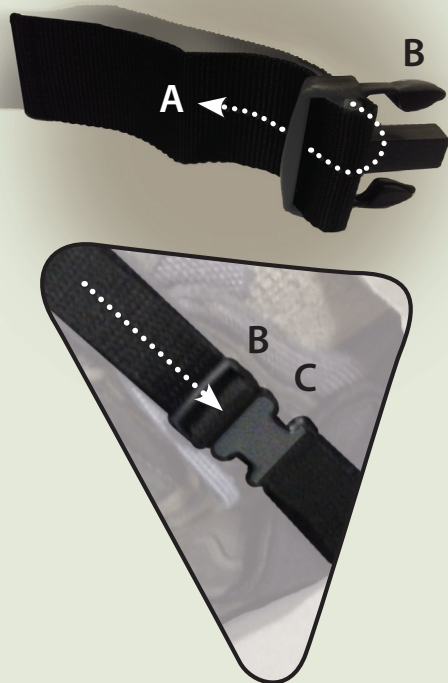

## Straps, Harnesses and Foot Plates (Operations)

To ensure the bike rider is safely secured, please adjust the seat, straps, and harnesses to the proper settings for the individual.



### RIGID AND NEOPRENE VELCRO STRAPS

Straps help keep the rider's feet firmly in place.

1. Velcro foot straps loop through the ring (D).
2. Pull to tighten and then press strap together so Velcro can lock in place.
3. To remove foot, simply peel apart Velcro straps.

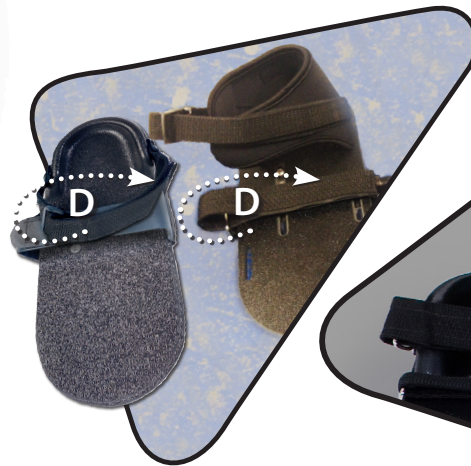

### TOE-UP PULLEY TENSION ADJUSTMENT

The position on the toe-up pulley rope can be easily adjusted by simply loosening the tension on the rope lock (F) and shifting it's position up or down the rope to the desired location. Once determined, tighten the tension back on the rope lock.

Then double-check the position of feet and make any necessary minor adjustments by repeating the process.

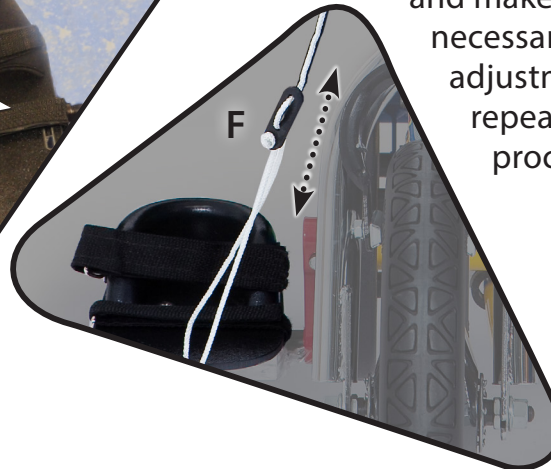

### FOOT PLATE ADJUSTMENTS

Our Neoprene foot plates allow for quick and easy adjustments to properly match the individual's hip to foot ratio. Loosen the four foot plate screws (J) and shift the foot plate (K) forward or backwards. Once the desired position is determined, re-tighten the screws in place to the pedal base.

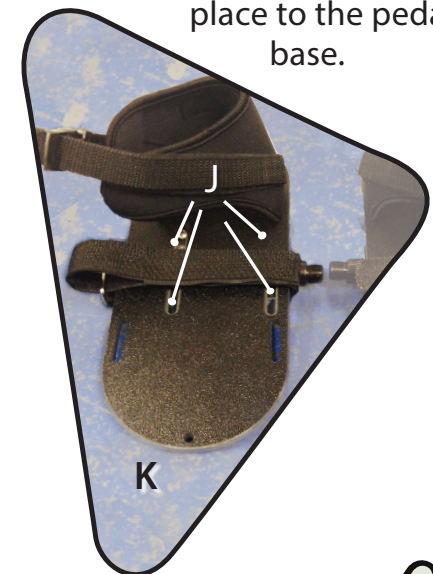

## Always wear shoes when riding to protect the feet.

Secure the foot first by positioning the heel at the back of the foot plate (G) and then attaching the straps (H) around the foot until snug.



### Learn More With Our How-To Videos.

Scan the QR Code with your phone and you will be linked to our Ready to Ride Video Series.



5

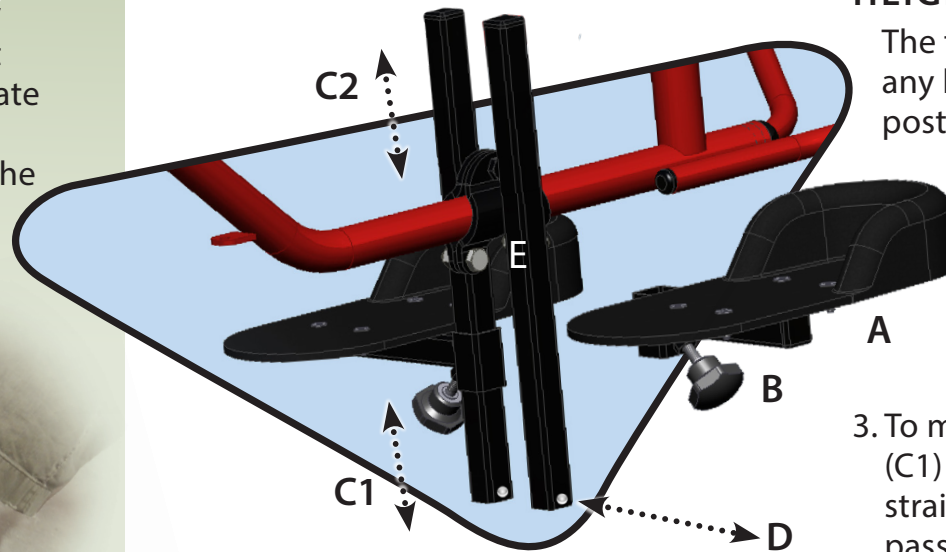

### RATCHETING FOOTPLATE ADJUSTMENT

To tighten the straps, flip the buckle tab (I) upwards to the desired tightness and fit.

To release the straps, pull the tab labeled "Pull to Open" (J) and lift the strap free from the buckle.



### HANDCYCLE FOOTPLATE HEIGHT ADJUSTMENT

The fixed footplates can be positioned vertically at any height, along the top or bottom, of the vertical posts.

1. To move the footplates (A), turn the thumbscrew (B) under each footplate counterclockwise until loose.
2. Then slide the footplate (A) up or down the post (C1 or C2) to the desired height. Retighten the thumbscrew (B).
3. To move the footplates (A) from the bottom post (C1) to the top post (C2) simply push the button (D) straight into the bottom post so the footplate can pass freely. The safety push button is provided to ensure you do not lose the footplates should you not tighten the thumbscrews (B) properly.
4. The frame clamp can also be adjusted to move the footplates forward or backwards. Two 1/2" (13mm) wrenches are required to loosen the bottom clamp bolts (E) for repositioning to the desired location on the bike.



### CHEST HARNESS STRAPS

Four #2 Robertson wood screws (F) are used to secure the chest harness to the seat back.

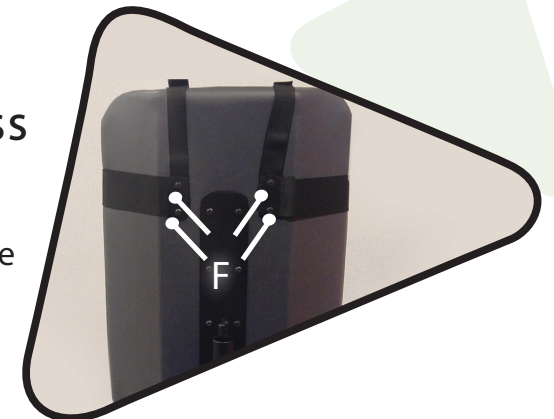

## **! WARNING**

**Seat lap belt must always be worn with the chest harness.**

Proper use of chest, lap, and hip belts ensures trunk stability and promotes safe positioning.

### **ADJUSTABLE HEAD REST**

1. Loosen thumb screws (I) on both sides of seat.
2. Raise or lower head rest (J) to desired setting for proper trunk and head heights.
3. Tighten thumb screws.

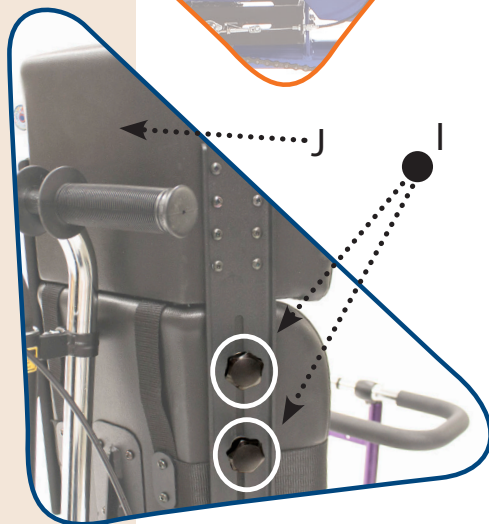

## **Seats (Adjustments and Operations)**

Seats come with different optional adjustments. Please refer to the following pictures for an understanding of the different adjustments available.

*\*See page 9 for quick release lever tension adjustments.*

### **SEAT HEIGHT ADJUSTMENT**

1. Open the quick release latches (A & B) at the front and back of the seat base.
2. With the latches open you can raise or lower the seat base (C) to your desired position.
3. Close the quick release latches (A & B) to clamp the seat base in the new position.

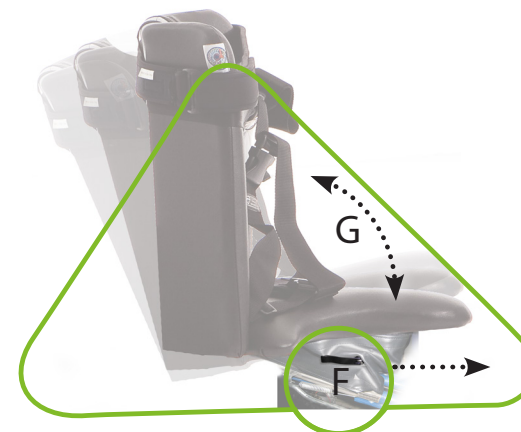

### **SEAT TILT ADJUSTMENT**

1. Open quick release latches (F) found on both sides, at the front of the seat base.
2. Tilt seat to desired position (G).
3. Close quick release latches (F) on both sides of seat to clamp seat tilt at a new position.



### **SEAT BASE LOCATION ADJUSTMENT**

1. Pull out seat base locking handle to release seat position (D).
2. Slide seat forward or backward to desired new location (E).
3. Close locking handle (D) and push seat back to ensure locked position.



Opened lever



Closed lever

## T-BAR SEAT INSTALLATION

1. Ensure both seat quick release levers are open before installing the seat.
2. Lift the seat into position, installing the front seat post (D) first. (Quick release nuts may need to be loosened if the seat posts don't slide in.)
3. To lock the seat in place, close both quick release levers.
4. Before tightening the clamp bolt (E), make sure the T-Bar handle (F) is parallel to the back rest. Using 6mm hex key tighten T-Bar clamp bolt (E). For bikes with Rear Steering, close the quick release on the bottom clamp.

## SEAT HEIGHT ADJUSTMENT

1. Open both quick release levers (A & B).
2. Adjust seat position to desired height (C).
3. Close both levers to clamp seat in position.  
*\*See page 9 for quick release lever tension adjustments.*



E

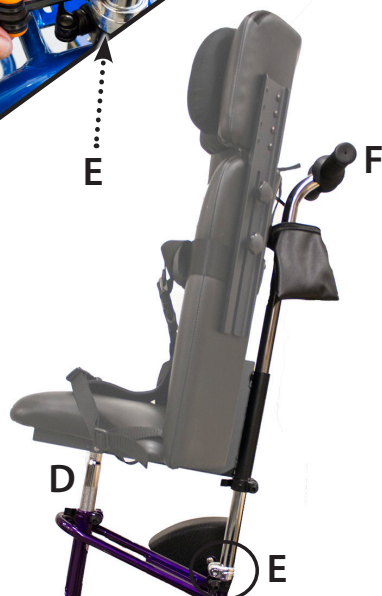

D

E

SEATS

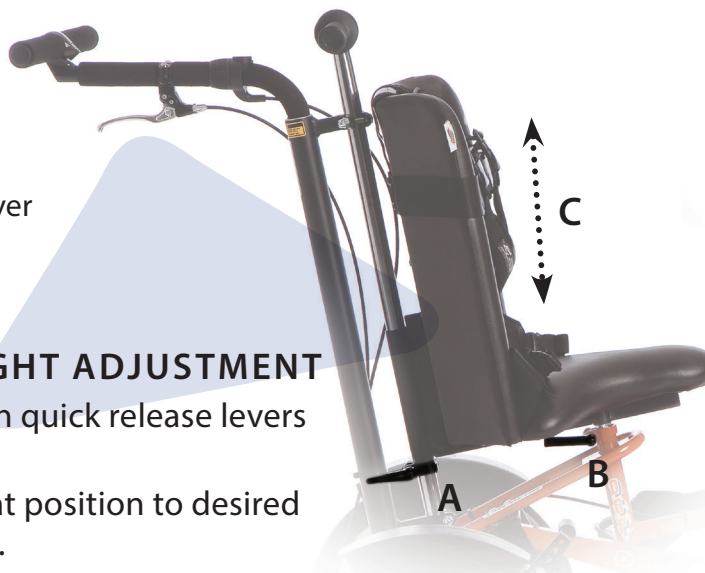

A

B

C



## HEAD SUPPORT HARDWARE

Head support must be personally set exclusively to each individual's needs. See detailed product manual for proper hardware installation and adjustment settings.



## SWING AWAY LATERAL TRUNK SUPPORT

The red push button (G) allows the Lateral Pad to flip out of the way when getting on or off of the bike.

The pad is reversible on the bracket for soft or firm support. Simply remove pins (H) on both sides of the pad by pulling. Switch pad as desired and then push in pins to lock back in place once again.

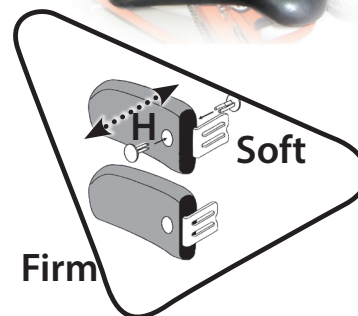

Firm

Soft

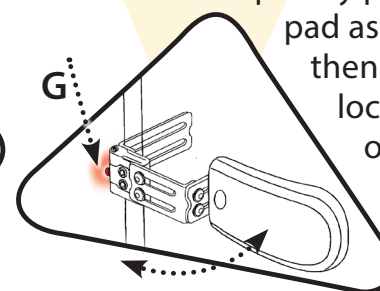

G

H





### SELF-CENTERING SPRING

Periodically check the self-centering spring to ensure proper tension. It is located on the bottom of the bike frame and connects to the fork on the front wheel. If the bike is not moving in a straight direction then the spring should be replaced.

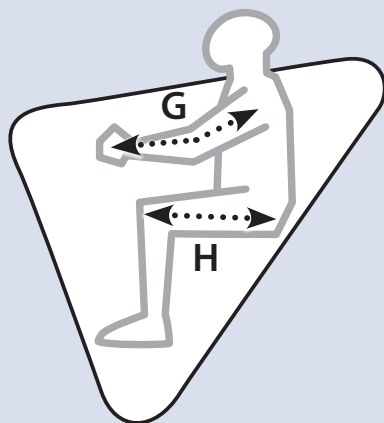

## Steering (Adjustments and Operations)

All steering should be adjusted to individual needs. On the following pages we have provided some quick reference guides to help you with your steering requirements.

### HAND DRIVE STEERING COLUMN POSITIONING

Easy adjustments (F) can be made on the Upright Handcycle to determine the ideal hand pedal positioning and to allow for ease with transferring on and off the bike.

### RIDING

The ideal position for the hand pedals is more of a personal choice. Our recommendation though, is to have the hand pedals moved in towards the rider until there is a slight bend at the elbow (G) when they are grasping the hand pedal at its furthest position, away from the chest.

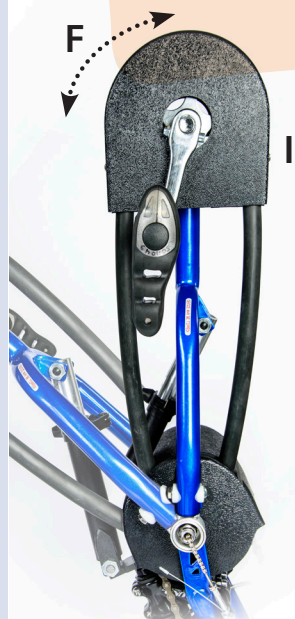

This is based on using a starting point where the knees and hips are in a horizontal plane (H) with the seat of the bike in the lowest possible position.

### TRANSFERRING

For easier transfers on and off the bike, the crank bracket should be positioned as far away from the seat as possible (I).

### HAND DRIVE STEERING ADJUSTMENT RELEASE

To swing hand pedals towards or away from the seat you need to do the following:

1. Hold the top steering column (J)
2. Open quick release lever (K)
3. Position top steering column to desired position and close quick release lever.

*\*For a better understanding on how to work the quick release lever see page 9.*

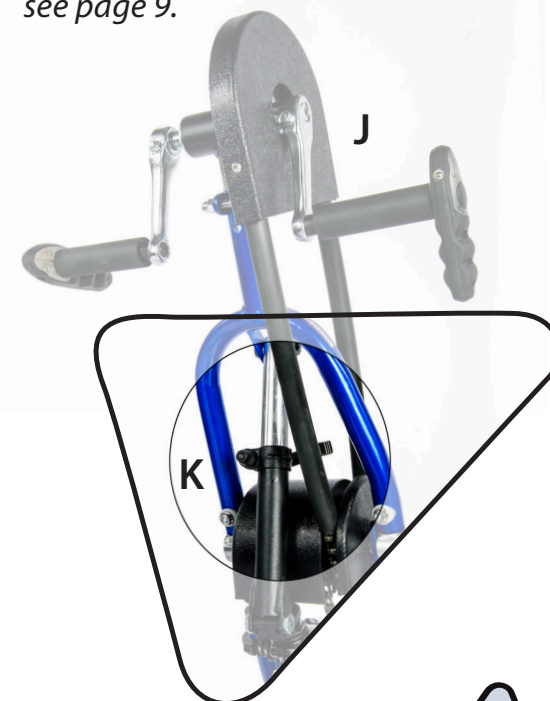

## Quick Release Lever Adjustments

From time-to-time you may need to adjust the tension on your quick release levers.

1. Open lever (G), and rotate lever handle (H) clockwise to tighten, or in the opposite direction to loosen tension, while holding nut with other hand.
2. Once set, close the lever to lock in place. If lever handle cannot close, loosen tension by opening the handle and turning counter-clockwise to desired setting.

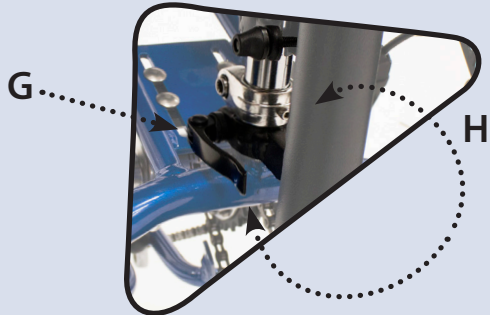

## HANDLEBAR/GRIP ADJUSTMENTS

1. To adjust handlebars in or out, loosen 6mm socket head wedge bolt (A), approximately 4-5 full turns.
2. Tap bolt (A) lightly with a hammer to unlock wedge nut (A1) from within handlebar shaft.
3. Turn handlebar shaft (B) to desired position and then tighten wedge bolt (A) until snug.
4. To adjust the grip, loosen 6mm socket head clamp bolt (C) and raise or lower the handlebar grip (D) to desired height.
5. Retighten clamp bolt (C).

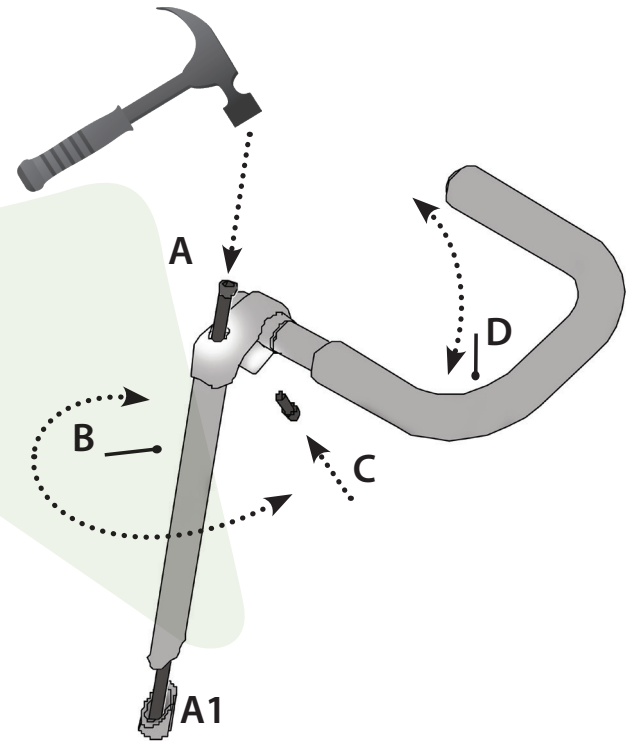

## "U" BAR FRAME ADJUSTMENT\*

Loosen quick release lever (F) to the unlock position for adjustment of the "U" bar frame. Move forward or backward to desired position. This is an excellent way to move handlebar assembly out of the way when transferring riders.

*\*Please note: In cases of extreme high tone the quick release lever may need to be replaced with the standard bolt and nut. Part # bolt: 4110440 Part # nut: 4130254*

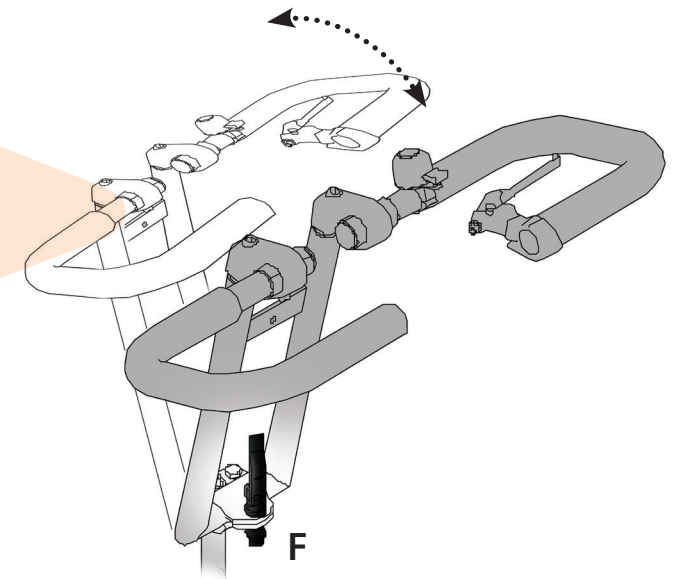

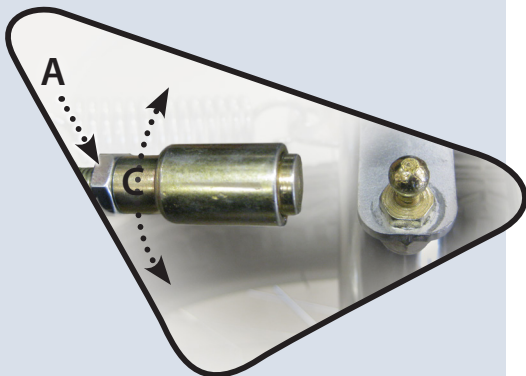
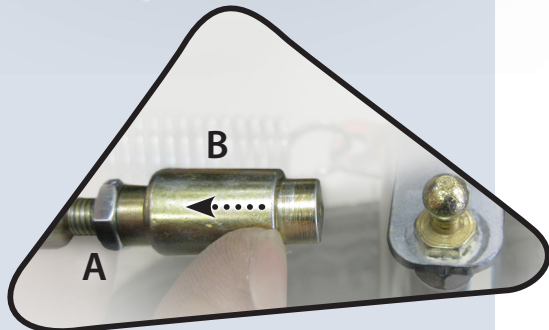

## REAR STEER HANDLE TENSION ADJUSTMENT

To adjust the tension or re-install after shipping:

1. Loosen locking nut (A) with 7/16" (11mm) wrench.
2. Slide outer barrel (B) of tie-rod towards locking nut to release from the ball joint, lifting up to disconnect.
3. Turn inner barrel (C) clockwise 1/2 to 1 full turn at a time to increase tension on steering.
4. Slide outer barrel of tie-rod towards locking nut and reconnect to ball joint.
5. Tighten locking nut (A).

*\*Disconnecting the rear steer handle during transportation of your bike will release the tension on the steering mechanism and allow the rear handle to turn out of the way—requiring less space for transportation.*

## ADJUSTABLE REAR STEERING HANDLEBAR COLUMN

Rear steering column can be folded to allow for ease of transportation and storage.

1. Pop open quick release lever handle and pull outward (F) to release spring lock.
2. Tilt steering column on hinge bracket.
3. To re-attach column, simply tip upward and tighten quick release.

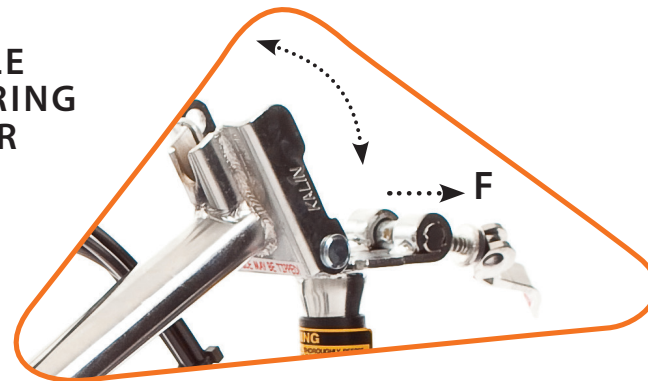

## Need A Little Extra Help Or Don't Understand Something?

Our service department is glad to help!  
Give us a call at:

**1.800.661.9915**

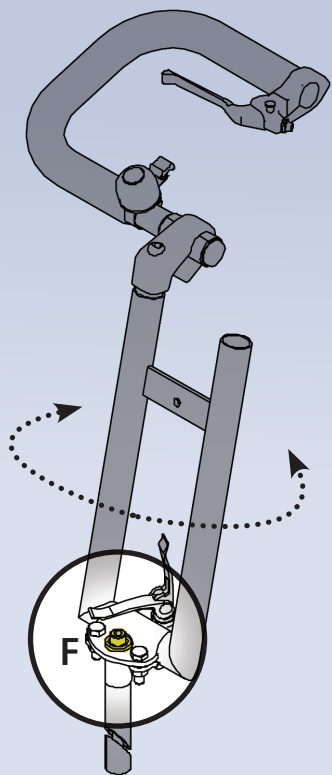

### STEERING ALIGNMENT

Loosen 1/2" hex head stem bolt (F) approximately 4-5 turns, tap lightly with hammer, and rotate steering column left or right to align steering with front wheel.

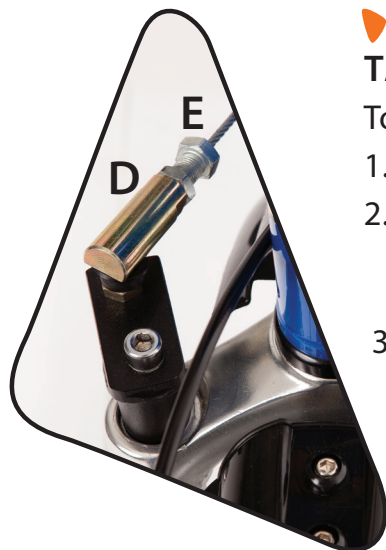

### TANDEM CONNECTED CABLE TENSION ADJUSTMENT

To adjust cable tension:

1. Loosen locking nut (D) with 9/16" (14mm) wrench.
2. Adjust the tension nut (E) with the same 9/16" (14mm) wrench. Turn the nut clockwise to tighten and counterclockwise to loosen cable.
3. Once desired tension is determined, tighten locking nut (D).

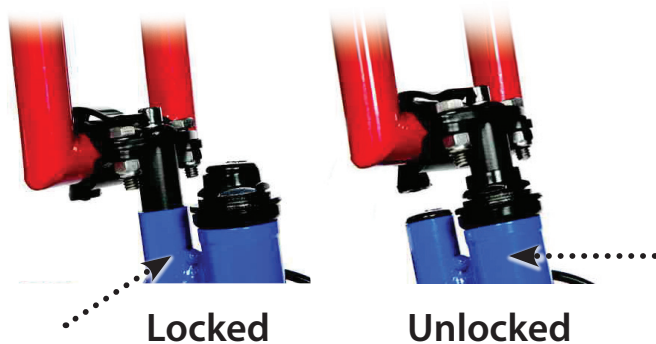

### LOCKED/UNLOCKED STEERING ADJUSTMENT

1. When locked, the steering mechanism is fixed in position. Rear Steering™ is required to steer bike when steering is locked.
2. When unlocked, it is fully functional.

### Handlebars with Toe-up Pulley

See page 4 for loosening toe-up pulley when moving handlebars out of the way.

### Learn More With Our How-To Videos.

Scan the QR Code with your phone and you will be linked to our Ready to Ride Video Series.



## Gear Shifting (Adjustments and Operations)

All Freedom Concepts' adaptive bicycles are adjustable to individual needs. Provided are some quick reference graphics to help you with your shifting requirements.



### AA: HAND GRIP SHIFTER OPERATION

Rotating the Revo-shifter (A) up towards the “-” sign will lower the gear for easier pedaling. Rotating down towards the “+” sign will increase tension when pedaling.

*Please note: When changing gears with the hand grip shifter one must pause from pedaling. Once desired gear is selected, pedaling can recommence.*



### BB: HAND GRIP / INTERNAL GEAR BOX HUB ALIGNMENT

To align hand grip shifter with the gear box hub adjust the following:

1. Shift hand grip shifter to gear “4” (B).
2. Check Nexus hub for alignment of yellow markers (C).
3. If yellow markers are not in alignment, turn the barrel adjuster (D) until both lines are equal.

*Please note: Any major repairs should be handled by a qualified bike repair shop.*

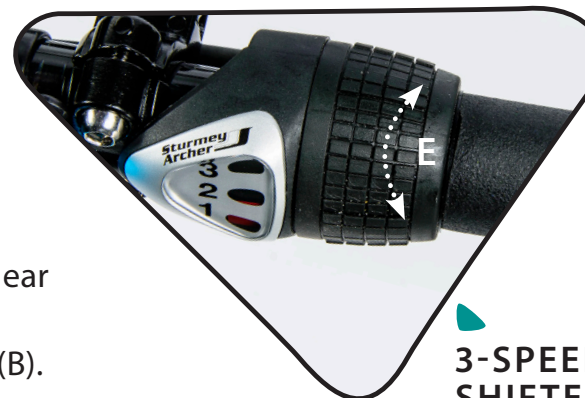

### 3-SPEED HAND GRIP SHIFTER OPERATION

Rotate shifter (E) up towards the “3” to increase tension when pedaling. Rotating down towards the “1” sign will decrease tension when pedaling.

*Please note: When changing gears with the hand grip shifter one must pause from pedaling. Once desired gear is selected, pedaling can recommence.*

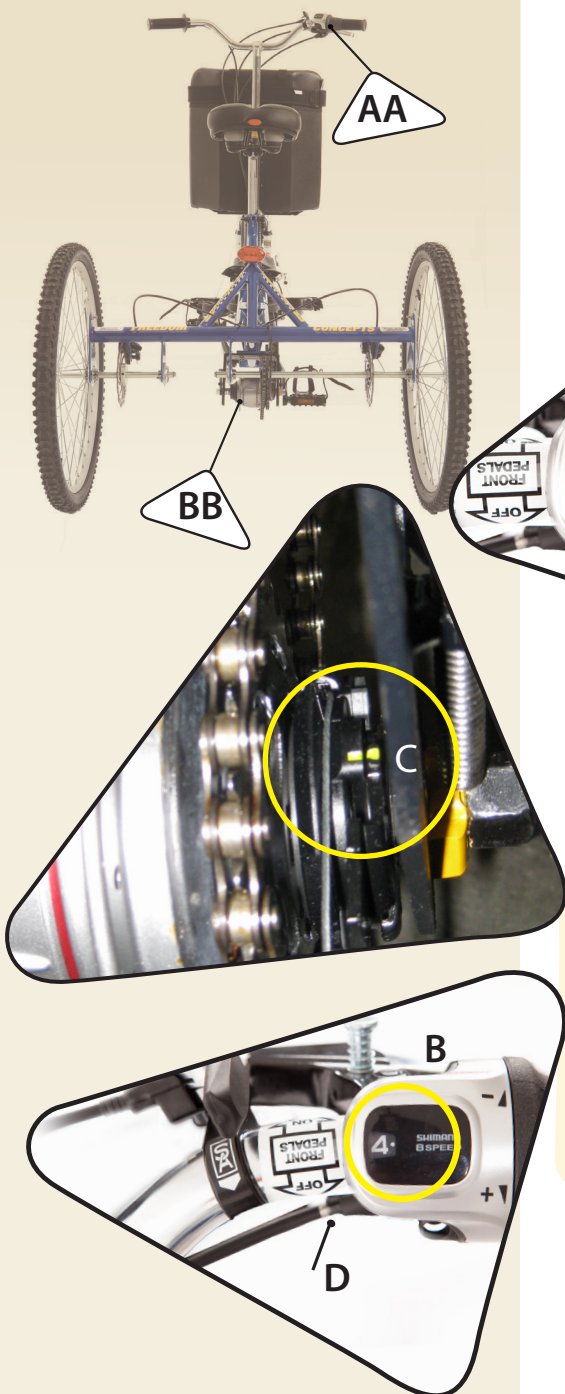

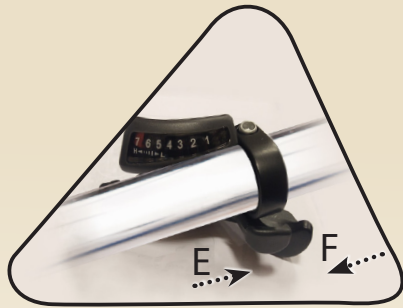

### THUMB/FINGER GEAR SHIFTER OPERATION

Change gears up or down with an easy click. Using your thumb, push shifter lever (E) forward. With each click you raise a gear. Using your finger, pull shifter lever (F) and with each click, you lower a gear.

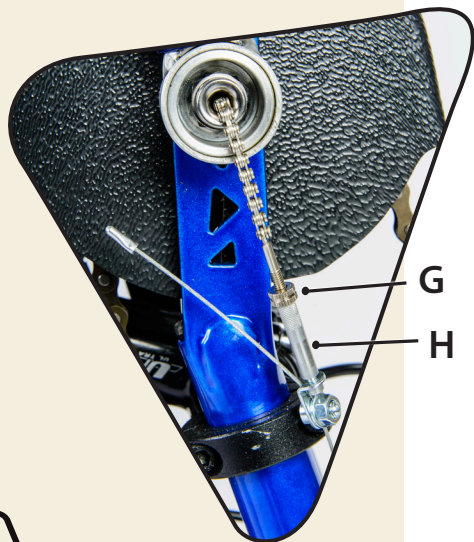

### THUMB PEDAL CONTROL SHIFTER OPERATION

Tandem bikes allow the option for both riders to pedal the bike at the same time. When the shifter (A) on the handlebar is closest to the rider the (B1) setting has the front sprocket in a neutral position and the front rider doesn't contribute to the propulsion of the bike. Pushing the shifter (A) forward once to the (B2) position engages the front sprocket at a low setting so the front rider can contribute. Moving the shifter (A) forward once again to the (B3) position changes the sprocket to the high setting for more contribution from the front rider. Moving the shifter in reverse adjusts the setting back to the beginning.

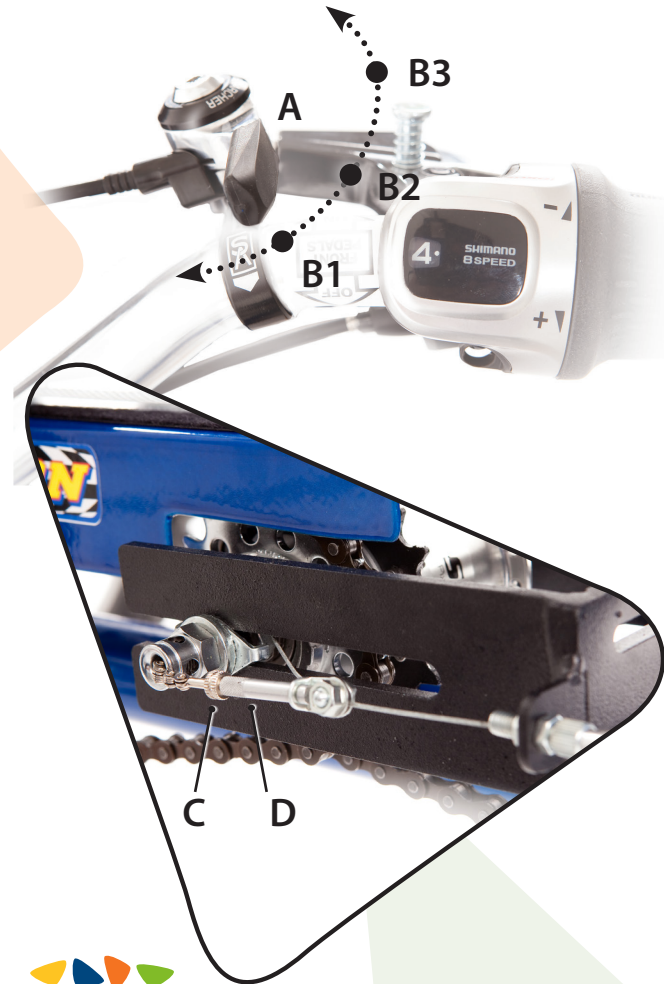

### 3-SPEED CABLE ADJUSTMENT

If the cable starts to stretch through normal use, quick adjustments can retighten the slack.

1. Shift to gear three.
2. Loosen lock nut (G) and turn barrel adjuster (H) until loose slacking cable is tight.
3. Tighten lock nut (G).

### REAR CONTROL GEAR TRANSFER

If the cable starts to stretch through normal use, quick adjustments can retighten the slack.

1. Shift to neutral position (B1).
2. Loosen lock nut (C) and turn barrel adjuster (D) until loose slacking cable is tight.
3. Tighten lock nut (C).

## ELECTRONIC ASSIST MOTOR

Did you know we offer the option of electric assist motors? They are ideal for those who take extended bike rides or for those who need assistance on inclines or when tandem riding. Ask your rep today to learn more.



## REAR SPROCKET ADJUSTMENT

Check set screw (A) periodically for tightness. Use 1/8" Hex Key wrench. This ensures good propulsion of the bike at all times.

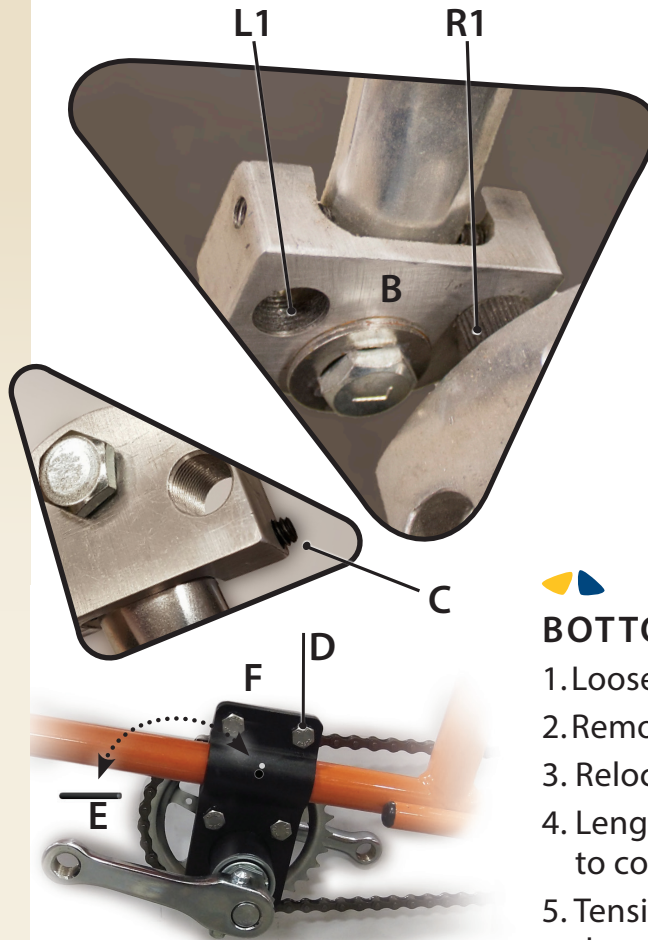
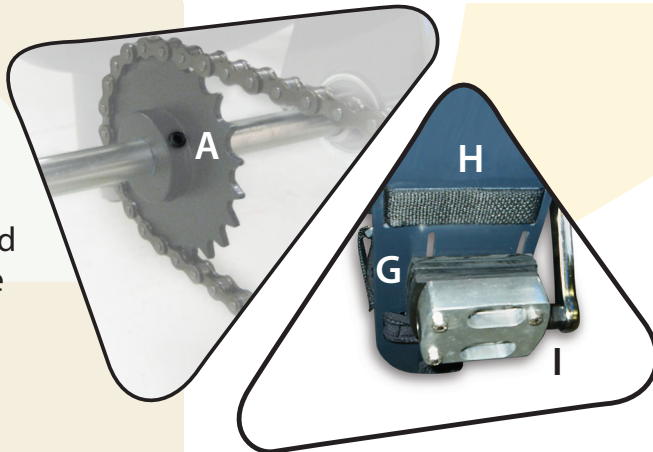

## CRANK ARM LENGTH SHORTENER

A multi-length crank shortener is used for greater adjustability of the range of motion.

1. Bolt adapter (B) to crank arm. Ensure locking support channel on adapter is facing crank arm to secure adapter in place. Tighten set screw (C) to lock in place.
2. Attach pedal in appropriate adapter hole for desired range of motion. The right pedal goes in hole (R1), left pedal in hole (L1).



## BOTTOM BRACKET AND CRANK ADJUSTMENT

1. Loosen 4 bracket bolts (D).
2. Remove roll pin (E).
3. Relocate bottom bracket (F) to desired position.
4. Lengthen or shorten chain with a chain break tool to correct length (sold separately).
5. Tension chain by moving bottom bracket (F) forward until there is no slack in the chain.
6. Tighten bolts (D), drill new hole in frame for roll pin using bracket hole for a guide and replace with new 1/8" roll pin



## PEDAL SPACERS

1. Stack spacers (G) between foot plate (H) and foot pedal base (I).
2. Secure from the top with supplied screws (J) through foot plate, spacers and into foot pedal base.



## SEATING DEDICATED TO YOUR COMFORT, SUPPORT AND STYLE.

Chill-Out Chairs assist with a wide range of behavioral and therapeutic needs. Every Chill-Out Chair is built with a combination of high-grade foams to help relax spastic muscles and provide the most comfortable sitting experience possible.



LEARN MORE AT:  
WWW.CHILL-OUTCHAIR.COM

## Braking (Adjustments and Operations)

All Freedom Concepts' adaptive bicycles are adjustable to individual needs. Provided are some quick reference graphics to help you with your braking requirements.

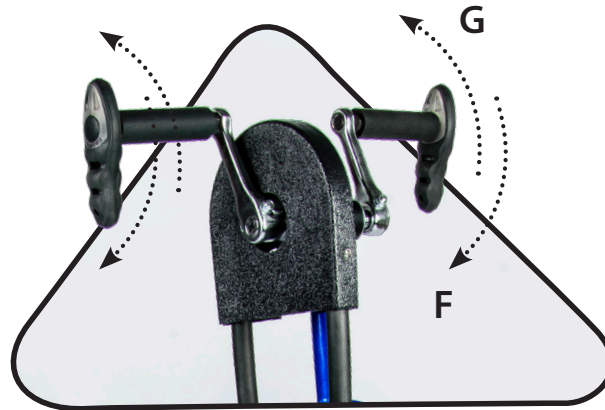

### HAND COASTER BRAKE

Just like the conventional foot coaster brake design, stopping is created by changing your direction backwards (F) from which you are pedaling (G).

### Learn More With Our How-To Videos.

Scan the QR Code with your phone and you will be linked to our Ready to Ride Video Series.



### DISC BRAKE TENSION ADJUSTMENTS

1. Loosen the locknut (A) on the hand brake by turning counterclockwise.
2. Turn the barrel adjuster (C) counterclockwise to tighten tension or clockwise to loosen to desired tension. Then tighten (A).
3. Adjust disc brake at wheel by turning locknut (B) counterclockwise to loosen.
4. Alter barrel adjuster (D) to desired setting by turning counterclockwise to increase brake sensitivity or clockwise to decrease.
5. Tighten locknut (B).

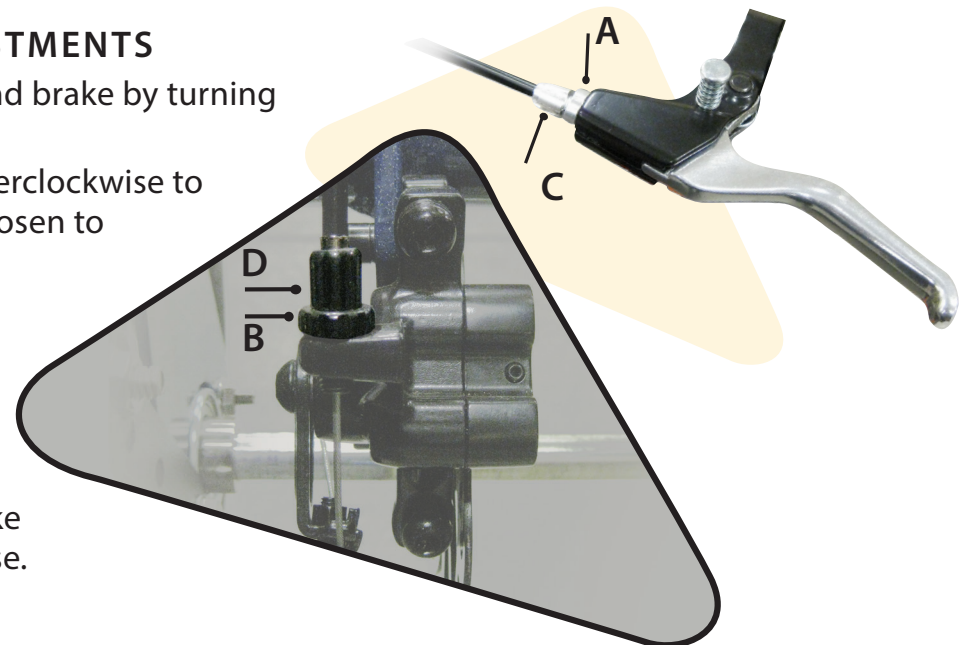



## ! WARNING

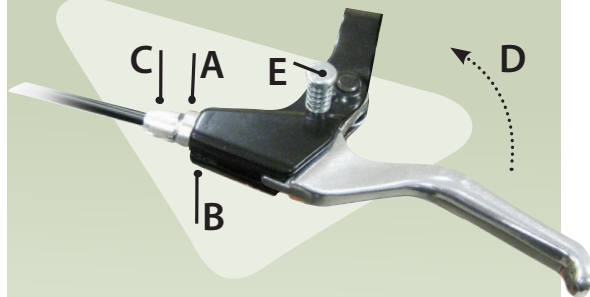

When transferring someone on or off the bike, always squeeze brake handle (D) and push in pin (E) to lock brake. This helps to stabilize the bike. To release brake lock, squeeze handle (D).



## REAR PARKING BRAKE

(Not available for DCP Mini's, ET2611 or the AS2600)

Parking brakes are available for one or both rear wheels on most bike models. Parking brakes are ideal for transporting riders on or off the bike, by stabilizing the bike movement. To use the parking brake, simply push the brake lever down to lock and lift up to release.



## AA: HAND BRAKE TENSION ADJUSTMENTS

1. Loosen the locknut (A) by turning away from housing (B).
2. Turn the barrel adjuster (C) towards the housing to loosen and away to tighten brake sensitivity.  
*Please note: when squeezing to apply the brakes, the brake lever should not touch the handlebar.*
3. Turn locknut (A) clockwise until tight.

*Caution: Over-tightening cable will cause brake pads to constantly rub on wheels.*

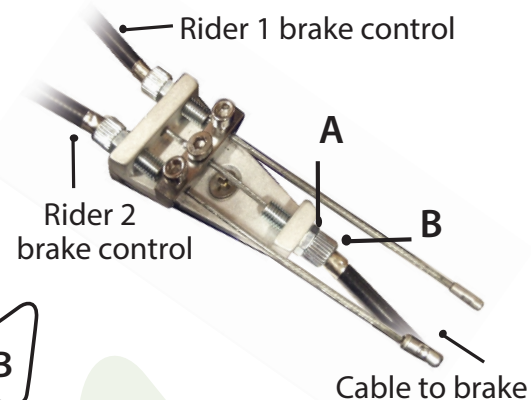
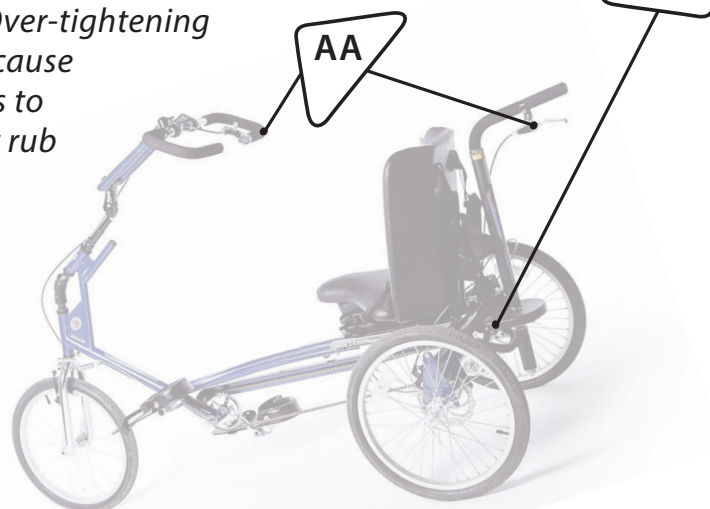

## BB: DUAL BRAKE CABLE JUNCTION BLOCK ADJUSTMENTS

1. Loosen the locknut (A) by turning counterclockwise.
2. Turn the barrel adjuster (B) clockwise to tighten and counterclockwise to loosen brake sensitivity.  
*Please note: When squeezing the brake lever to apply the brakes, the lever should not touch the handlebar when closed.*
3. Turn locknut (A) clockwise until tight.

*Caution: Over-tightening cable will cause brake pads to constantly rub on wheels.*

*For instructions on cable adjustments to the calipers, follow caliper brake tension adjustments on page 17.*

## ! WARNING

Always ensure brake pads only touch the rim of the wheel. Pads touching the tire can cause flats.

### Learn More With Our How-To Videos.

Scan the QR Code with your phone and you will be linked.

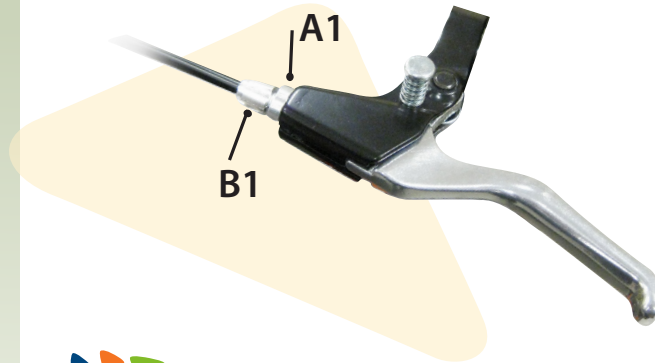

### V- BRAKE TENSION ADJUSTMENTS

1. Loosen the locknut (A1) on the hand brake by turning counterclockwise.
2. Turn the barrel adjuster (B1) counterclockwise to ensure brake pads stop tire from spinning when hand brake is squeezed and do not rub when released.



*Please note:  
Any further cable repairs should be handled by a qualified bike repair shop.*

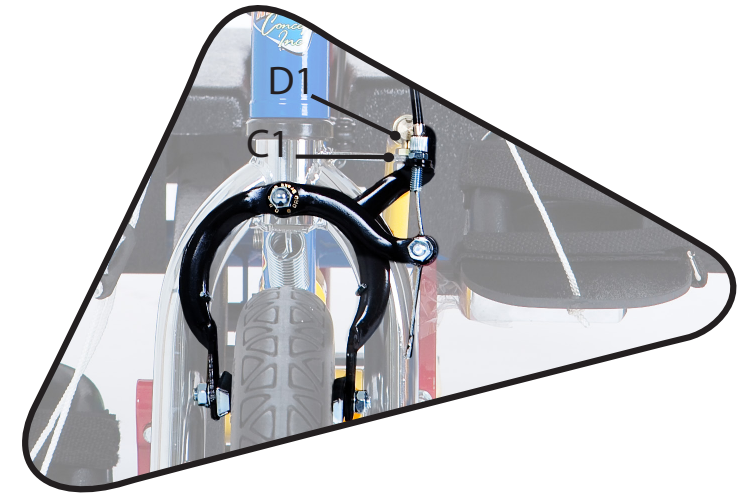

### CALIPER BRAKE TENSION ADJUSTMENTS

1. Loosen the locknut (A1) on the hand brake by turning away from housing to allow for fine tune hand brake adjustments.
2. Turn the barrel adjuster (B1) counterclockwise to ensure brake pads stop tire from spinning when hand brake is squeezed and do not rub when released.
3. Loosen locknut (C1) on caliper brake.
4. Turn the barrel adjuster (D1) away from the housing to bring pads closer to rim to ensure brake pads stop tire from spinning when hand brake is squeezed and do not rub against the rim when released.
5. Tighten (A1 and C1).

## Removable Rear Wheel\*

\*Available only in 20" (50.8 cm) models.

### TO RELEASE THE WHEEL:

Open the quick release handle and rotate counterclockwise until it is completely off the drive shaft, and pull wheel out.

### TO REPLACE THE WHEEL:

Insert and align wheel hub on axle dowel pin and insert quick release bolt, tighten and close handle to lock.

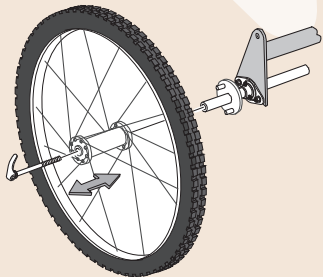

## Wheels And Tire Systems

Depending on the model of bike you own, there are a variety of different wheels and tires available to you.

### TIRE OPTIONS

For the best tire traction, we offer a variety of options to fit your individual needs. Our smooth tires are ideal for the city streets and indoor riding. Our knobby tires work best for the rugged riders or off-road enthusiasts. Always keep tire pressure inflated to manufacturer's recommended pressure as shown on the side of tire. For maintenance-free riding, we offer the option of solid tires with the custom Freedom Concepts gripper tread. The solid tires are ideal for multi-user environments, as they never go flat.

*Please note: Not all tires are available in all sizes. Check online at [www.freedomconcepts.com](http://www.freedomconcepts.com) for availability on each model.*



**KNOBBY TIRES**



**SMOOTH TIRES**



**SOLID TIRES**



### WHEEL OPTIONS

We offer a variety of different wheel options. Aluminum, steel and ABS plastic.

*Ask us about our different spoke covers to protect little fingers.*

## Maintenance

1. Keep tire pressure inflated to manufacturer's recommended pressure shown on the side of tire.
2. Keep bearings properly lubricated at all times to ensure smooth rotation and lasting operation.
3. Make sure all bolts and screws are tight.
4. Always keep chain lubricated.
5. Always keep bike clean and dust free.
6. Keep bike out of severe weather conditions.
7. Ensure that at least 4" (10 cm) of seat post is in the seat tube of frame. DO NOT raise seat post past maximum height indicator.
8. Adjust brakes regularly to ensure proper stopping.
9. Adjustments can be made using the **Freedom Concepts Multi-Tool**, which is shipped with all orders.



## Customized Options

To help get the most out of your cycling experience, we offer additional items and accessories for your customization needs.

### ***Don't see something you need or want?***

Give us a call! We pride ourselves on making your experience as enjoyable as possible, and are constantly developing new products and items based on our clients' requests. The item you are looking for might be in development right now!



### **NEOPRENE CHEST HARNESS**

To accommodate your child's growth, we offer chest harnesses in a variety of sizes (medium, large and extra large). *Ask about our overnight delivery to ensure they never have to stop enjoying outdoor adventures and fresh air.*

### **STATIONARY TRAINER**

Don't let the weather slow down your exercise program. Take advantage of our Indoor Stationary Trainer and you can ride each and every day, no matter what the weather looks like outside. Ask us about shipping options to determine the best means for delivery.

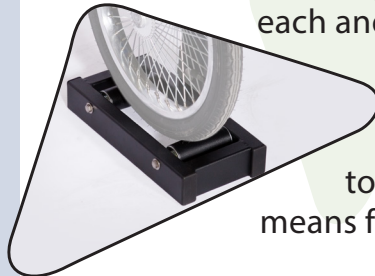

### **ABDUCTOR /ADDUCTION LEG SUPPORTS**

Padded leg adduction straps (A) or removable abductor leg dividers (B) help riders to maintain proper leg alignment and maximize each bike ride.

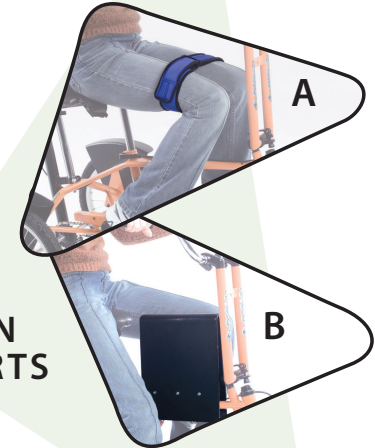

### **COMMUNICATION TRAY**

Now non-verbal riders can carry their assistive technology devices for communicating with those around them. Our handy communication tray can mount firmly to the bike when used with the handlebar system in the locked position.



## Accessories

Looking for something special? Listed below are some of the many items we feature on our website. Visit us at [www.FreedomConcepts.com](http://www.FreedomConcepts.com) to learn more.



Multi-Tool



Adjustable Tilt Fork



Ratcheting Footplates



Bike Cover



Cane/Crutch Holder



Sun Shade Canopy

- Safety Flag
- Wheel Reflectors
- Squeaky Animal Horns or Bells
- Velcro Hand-Eye Gloves
- Bike Cover
- Tool Pouch
- Water Bottle & Holder
- Multi-Tool
- Electric Assist Motor
- Cane/Crutch Holder
- Oxygen Tank Holder
- Sun Shade Canopy
- Communication Tray
- Custom Headrests
- TEC/REC Drives
- Pedal Blocks
- Rear Platforms *and more!*



Squeaky Animal Horns



This warranty is made expressly in place of all other guarantees or warranties, expressed or implied, statutory or otherwise, including without limitation those with respect to quality, merchantability, or fitness for a particular purpose.

In no event shall Freedom Concepts be responsible for any losses or damages or any other type of liability including without limitation economic or consequential losses or damages, indirect, incidental or punitive damages, personal injury, or damage.

© 2018  
FREEDOM CONCEPTS INC.  
00007 (24/03/18)

## Freedom Concepts Warranty

Freedom Concepts Inc. (FCI) is pleased to offer quality mobility devices we custom manufacture. All component parts of our devices are inspected at various stages of production, and each product is subjected to a rigorous final inspection before being shipped.

Freedom Concepts provides a Standard Lifetime Warranty on all product frames. A two-year warranty is offered on parts and accessories. The warranty commences on the date the product is shipped to the customer. This warranty does not include repair or replacement required as a result of misuse, abuse, use for any purpose other than intended, damage resulting from commercial or institutional use, or from normal wear and tear. The defective part(s) must be returned through an authorized dealer. If the warranty claim is approved by Freedom Concepts, the defective parts will be replaced, however, shipping costs will incur. Repair by any unauthorized service representative relieves Freedom Concepts of further liability, or obligation under this warranty. The sole obligation of Freedom Concepts with respect to its products and parts and this warranty shall be, at the sole option of Freedom Concepts, to repair or replace the part or product if the warranty claim is approved by Freedom Concepts, at its sole discretion. The foregoing is the customer's sole and exclusive remedy with respect to this warranty.

All Freedom Concepts mobility devices have a 30-day Satisfaction Guarantee not including the return shipping costs, which are the responsibility of the customer.



Register online at: [www.freedomconcepts.com/warranty](http://www.freedomconcepts.com/warranty)

All products and services are subject to change at anytime without notice, at the sole discretion of Freedom Concepts Inc. Freedom Concepts reserves the right to discontinue any product at any time.





Freedom Concepts was born from a special request to build a bike for a special needs child. This one bike was such a huge success that it opened the door to many new requests and the birth of a company. Today, bikes from Freedom Concepts can be found throughout the world. We continue to innovate and develop not only bikes, but other unique items like Chill-Out Chairs, climbers and strollers. Visit us online to see our latest creations or give us a call.

***“Give us a need, we will find a concept.”***



Ken Vanstraelen  
PRESIDENT

## Help Us Help Others And Be Rewarded!

We truly appreciate all the joy and happiness we can bring to others. Nothing is more gratifying than when we receive referrals from those who recommend our products. To thank all who refer new customers to us, we offer a reward program. If you recommend one of our Adaptive Bikes or a Chill-Out Chair to a customer and it results in a sale, you will receive **a check for \$250.00!**

Simply fill out the following form and either fax, email, or go online with us. Upon confirmation, a check will be in the mail. Once again, thank you for your support in helping us make life enjoyable for all!

Original Purchaser's Name:  
(YOUR NAME)

---

Your Bike Serial #

---

Your Email:

---

Referral Name:

---

Their Address:

---

Their City:

---

Their Prov/State:

---

Their Postal Code/Zip Code:

---

Their Phone Number(s):

---

**\$250.00**

Scan the QR Code with your phone to be linked to our referral page.



Phone: 1 (800) 661.9915 Fax: 1 (204) 654.1149 [www.freedomconcepts.com](http://www.freedomconcepts.com)

# SHARE YOUR FIRST RIDE WITH US!



*SEND US PICTURES OR VIDEO FROM YOUR FIRST BIKE RIDE TO BE ENTERED TO WIN COOL PRIZES LIKE IPADS, FREEDOM GEAR AND MORE!*

**SUBMIT TO: [MOBILITY@FREEDOMCONCEPTS.COM](mailto:MOBILITY@FREEDOMCONCEPTS.COM)**



**Call Us Today To Learn More: 1.800.661.9915**

[FREEDOMCONCEPTS.COM](http://FREEDOMCONCEPTS.COM)